



**PLANNING AND DEVELOPMENT DEPARTMENT MEMORANDUM  
#09-2020**

**DATE:** April 13, 2020  
**TO:** Honorable Mayor Meredith Leighty and City Council Members  
**THROUGH:** Heather Geyer, City Manager   
**FROM:** Brook Svoboda, Director of Planning and Development   
**SUBJECT:** CR-69 – RTD IGA for Column Tree Wraps at the North Metro Line 112<sup>th</sup> Avenue Station

---

**PURPOSE**

To consider a resolution authorizing the City Manager to enter into an Intergovernmental Agreement with the Regional Transportation District (RTD) for the District to install column tree wraps (betterments) on behalf of the City.

**BACKGROUND**

In 2016, the City requested betterments for the 112<sup>th</sup> Avenue Station in the form of column wraps to emulate the appearance of tree trunks for the station canopies. The overarching theme for the station was nature and trees. In working with the RTD and Regional Rail Partners (RRP), several iterations were presented to City Council that were deemed inadequate.

In 2017, RTD realized that RRP would not be able to deliver on the requested betterments for the City, and stepped in to assume the lead role with the knowledge that they had retained an on-call contractor whose work product was superior to any previous effort RRP had put forward.

RTD staff reached out and offered an alternate approach that would not include RRP, wherein RTD would self-perform the betterments with an RTD on-call contractor, Yetiweurks. Yetiweurks designed a concept, included as Attachment 1, which was presented to City Council in 2017 and was approved with an estimated budget of approximately \$80,000. This amount is included in the City's budget and has been carried over since being authorized by Council.

Initially, the installation of the column wraps was to occur in Q3/4 of 2017 when RRP was scheduled to turn over the station to RTD. The turnover of the station is currently planned for Q2 of 2020, approximately three years later. Due to the delay, RTD's on-call contract with the Yetiweurks has lapsed.

RTD staff recently received authorization to secure a sole source contract with Yetiweurks to install the column wraps; however, RTD's Procurement Division requires approval of the IGA with the City as a condition to utilize the sole source contract.

The IGA will allow RTD to honor their commitment to construct and install the City's betterments at the station.

**STAFF RECOMMENDATION**

Staff recommends approval of CR-69.

**BUDGET/TIME IMPLICATIONS**

This project is a budgeted item in the City's Capital Improvement Program.

**STAFF REFERENCE**

If Council members have any comments or questions, they may contact Brook Svoboda, Director of Planning and Development, at 303.450.8937 or bsvoboda@northglenn.org.

**ATTACHMENT**

1. Yetiweurks Rendering

CR-69 – RTD IGA for Column Tree Wraps at the North Metro Line 112<sup>th</sup> Avenue Station  
Intergovernmental Agreement

# ATTACHMENT 1

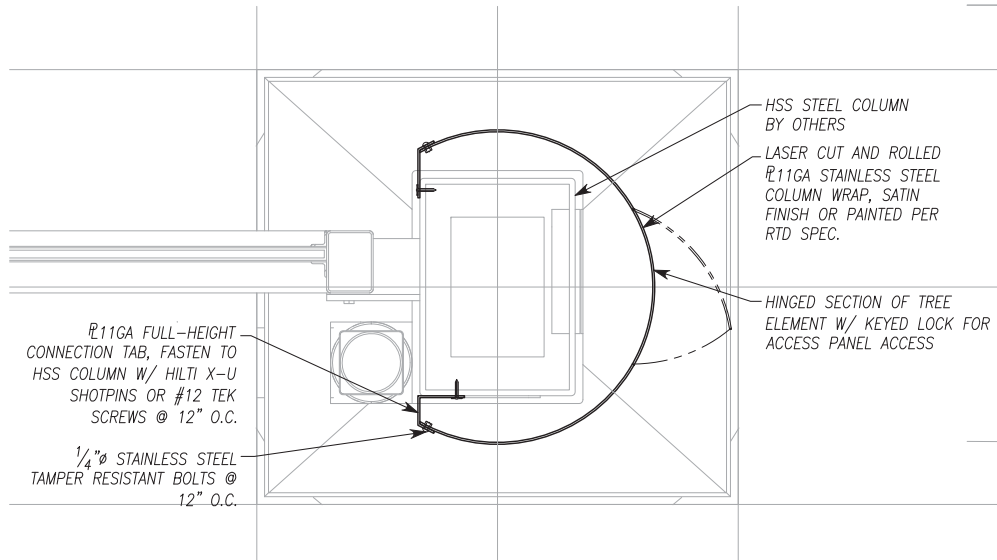

**2** COLUMN WRAP PLAN DETAIL  
SCALE :  $1\frac{1}{2}"=1'-0"$  1115DT001

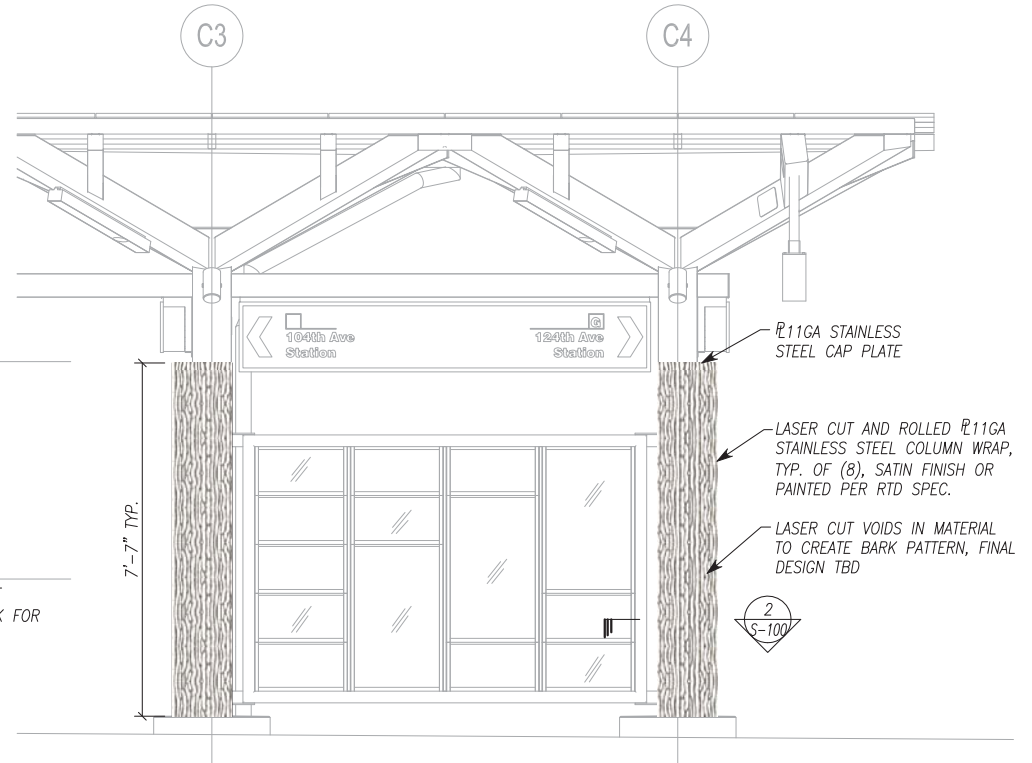

**1** COLUMN WRAP ELEVATION  
SCALE :  $3/8"=1'-0"$  XXXXT001

<p>ART + ENGINEERING 303.646.7553   yetiroot@gmail.com www.yetiweurks.com</p>	TITLE:	SCHEMATIC ELEVATION AND PLAN	<h2>S-100</h2>
	PROJECT NAME:	RTD - 112TH STATION COLUMN WRAPS	
	DRAWN BY:	NAG	
	SCALE:	AS NOTED	

DRAWING FILE NAME: XXXX-100 PLOT DATE: 09/26/2017

SPONSORED BY: MAYOR LEIGHTY

COUNCILMAN'S RESOLUTION

RESOLUTION NO.

No. CR-69  
Series of 2020

\_\_\_\_\_  
Series of 2020

A RESOLUTION APPROVING AN INTERGOVERNMENTAL AGREEMENT BETWEEN THE CITY OF NORTHGLENN AND THE REGIONAL TRANSPORTATION DISTRICT REGARDING THE INSTALLATION OF COLUMN TREE WRAPS AT THE NORTH METRO LINE 112<sup>TH</sup> AVENUE STATION

BE IT RESOLVED BY THE CITY COUNCIL OF THE CITY OF NORTHGLENN, COLORADO, THAT:

Section 1. The Intergovernmental Agreement between the City of Northglenn and the Regional Transportation District, attached hereto as **Exhibit 1**, regarding the installation of column tree wraps at the North Metro Rail Line 112<sup>th</sup> Avenue Station is hereby approved and the City Manager is authorized to execute same on behalf of the City.

DATED at Northglenn, Colorado, this \_\_\_\_ day of \_\_\_\_\_, 2020.

\_\_\_\_\_  
MEREDITH LEIGHTY  
Mayor

ATTEST:

\_\_\_\_\_  
JOHANNA SMALL, CMC  
City Clerk

APPROVED AS TO FORM:

\_\_\_\_\_  
COREY Y. HOFFMANN  
City Attorney

**INTERGOVERNMENTAL AGREEMENT**  
**BETWEEN**  
**THE CITY OF NORTHGLENN**  
**AND**  
**THE REGIONAL TRANSPORTATION DISTRICT**  
**REGARDING ARTWORK TREE WRAPS**  
**ON THE NORTHGLENN • 112<sup>TH</sup> STATION COLUMNS FOR THE NORTH METRO RAIL LINE**  
**PROJECT**  
**APRIL \_\_\_\_\_, 2020**

INTERGOVERNMENTAL AGREEMENT  
BETWEEN THE CITY OF NORTHGLENN AND THE REGIONAL TRANSPORTATION  
DISTRICT  
REGARDING ARTWORK TREE WRAPS ON THE NORTHGLENN • 112<sup>TH</sup> STATION  
COLUMNS FOR THE NORTH METRO RAIL LINE PROJECT

This Intergovernmental Agreement ("IGA") is made and entered into this \_\_\_ day of April, 2020 (the "Effective Date"), by and between the CITY OF NORTHGLENN ("City"), and the REGIONAL TRANSPORTATION DISTRICT ("RTD") for the purpose of defining the parties' respective roles and responsibilities in connection with the Artwork Tree Wraps on the Northglenn • 112<sup>th</sup> Station Columns on RTD's North Metro Rail Line Project.

**RECITALS**

**Whereas**, RTD, a political subdivision of the State of Colorado, is authorized, pursuant to C.R.S. 32-9-101, *et seq.* to develop, maintain and operate a mass transportation system for the benefit of the inhabitants of the District; and

**Whereas**, the City is authorized under the authority of its Charter and C.R.S. 29-1-201 to enter into this IGA; and

**Whereas**, pursuant to the Colorado Constitution, Article XIV, Section 18(2)(a), and C.R.S 29-1203, the Parties may cooperate or contract with each other to provide any function, service or facility lawfully authorized to each; and

**Whereas**, the North Metro Rail Line Project (the "Project") is identified in RTD's FasTracks plan approved by the voters of the District on November 2, 2004 and approved by the Denver Regional Council of Governments as per the requirements of C.R.S. 32-2-9-107.7; and

**Whereas**, RTD and the City support public art and agree that public artwork enhances the areas in which it is instituted as well as deters graffiti and cuts down maintenance costs; and

**Whereas**, the City has reviewed various proposals for the Artwork Tree Wraps and decided that the proposal that best meets the City's expectations and desires was submitted by Yetiweurks; and

**Whereas**, the City and RTD desire to enter into this IGA to document the respective roles and responsibilities of the parties in the implementation of artwork tree wraps on the Northglenn • 112<sup>th</sup> Station columns.

**AGREEMENT**

**NOW, THEREFORE**, in consideration of the premises and the mutual agreements set forth herein, the parties hereto agree as follows:

**ARTICLE 1  
PURPOSE AND SCOPE**

- A. The recitals set forth above are incorporated herein by reference.
- B. The Project is to be completed and opened to the public in 2020.

- C. The purpose of this IGA is to set forth the general rights, duties and obligations of the City and RTD to establish, manage and maintain the Artwork Tree Wraps.
- D. The City and RTD agree that each will fully cooperate and coordinate with the other on all such activities as are covered by this IGA.

**ARTICLE 2  
ARTWORK TREE WRAPS**

- 1. Funding:
  - a. Northglenn will provide funding up to \$80,000 to commission the Artwork Tree Wraps on the Northglenn • 112<sup>th</sup> Station columns for the North Metro Rail Line. The materials and labor of the Work to be provided by Yetiweurks.
- 2. Location:
  - a. All Artwork Tree Wraps will be on RTD property, confined to the Northglenn • 112<sup>th</sup> Station. The wraps will be the same as were previously proposed to the City by Yetiweurks.
  - b. The City has determined that all eight canopy columns at the Northglenn • 112<sup>th</sup> Station will receive the specific type of Artwork Tree Wraps as proposed.
- 3. Safety Training and RTD Operations Notification:
  - a. All contractors who will be installing or working within 15 feet of the tracks are required to take an on-line safety training class provided by RTD. There is no charge for the training.
  - b. All contractors are required to have a no-cost permit from RTD which notifies the train operators to watch out for activity along the line. Application for permit needs to take place a minimum of 1 week prior to installation.
- 4. RTD Responsibilities:
  - a. The RTD will be responsible for contracting, inspection, coordination, oversight and payment to the commissioned artist for the Artwork Tree Wraps at the Northglenn • 112<sup>th</sup> Station.
  - b. RTD will provide the locations and basic sizes of canopy columns, but Yetiweurks, the fabrication/installation contractor, is responsible for individual site visits to verify all measurements and nuances associated with the columns.
  - c. In no way, shall the structural integrity of the columns be compromised and they must be kept functioning as designed.
  - d. RTD does not require an additional layer of graffiti coating over the artwork.
  - e. It is understood that the artwork will be painted to match the existing color and paint specifications.
  - f. RTD will be responsible for maintenance of the artwork once it is installed and reserves the right to remove the artwork at any time deemed necessary by RTD after consultation and approval by the City, and such approval shall not be unreasonably withheld.

5. Payments and Reimbursements

- a. RTD shall invoice the City for contractual work completed and paid to the contractor by RTD up to \$80,000. Requests for reimbursement shall include copies of all contractor invoices.
- b. Reimbursement invoices to the City will be at major milestones of the Artwork installation at approximately 25, 50 and 100 percent completion.
- c. The City shall disburse funds to RTD within 30 days of receipt of RTD's invoices.
- d. In case the Contractor fails to meet RTD requirements, City is obligated to reimburse RTD on any accumulated funds.

**ARTICLE 3  
DISPUTES**

The Parties shall resolve disputes regarding all items in this IGA at the lowest staff level possible. The escalation process shall be: (i) the RTD Deputy Project Manager for the North Metro Corridor & the assigned liaison person for the City, (ii) RTD's North Metro Corridor Project Manager and the City's Director of Planning and Development, (iii) RTD's Assistant General Manager for Capital Programs and the City's Manager. Any dispute that cannot be settled shall be resolved by litigation in District Court for the City and County of Denver.

**ARTICLE 4  
PROJECT LIAISONS**

All communications required by this IGA shall be made to the following individuals:

To the City:                      Brook Svoboda  
   Director of Planning and Development  
   City of Northglenn  
   11701 Community Center Dr.  
   Northglenn CO 80233

To RTD:                              Chuck Culig  
   Project Manager  
   Regional Transportation District  
   1660 Blake Street  
   Denver, Colorado 80202

**ARTICLE 5  
MODIFICATION**

This IGA may be modified, amended, changed, or terminated in whole or in part, only by an agreement in writing duly authorized and executed by the parties.

**ARTICLE 6  
REASONABLENESS OF CONSENT OR APPROVAL**

Whenever the approval of either party hereto is called for under this IGA, such party shall be entitled to consider public and governmental policy in reasonably granting or denying such approval. Required approvals shall not be unreasonably withheld.



**ARTICLE 7  
APPROPRIATION BY THE CITY AND THE RTD BOARD**

Any and all obligations of the City and RTD under and pursuant to this IGA which require funding are subject to prior annual appropriations of monies expressly made by the City for the purposes of this IGA, and the Board of Directors of RTD for the purposes of this IGA. Nothing herein shall be construed as a multiple fiscal year obligation as described by Article X section 20 of the Colorado Constitution by either party.

**ARTICLE 8  
COMPLETE INTEGRATION; ASSIGNMENT; PRIOR AGREEMENTS**

This IGA is intended as the complete integration of all understandings between the parties as to the subject matter hereof and shall supersede any prior agreements, written or oral, concerning the subject matter herein. No prior or contemporaneous addition, deletion or other amendment regarding the subject matter herein shall have any force or effect, unless embodied herein in writing. No subsequent renovation, renewal, addition, deletion, or other amendment hereto shall have any force or effect unless embodied in a written amendatory or other agreement executed by the Parties. Neither party may assign this IGA without the prior consent of the other party. Notwithstanding the foregoing, this IGA and any amendments thereto shall be binding upon the Parties, their successors and assigns. Notwithstanding anything to the contrary herein, this IGA shall not be deemed to obviate, negate or supersede the provisions of any other intergovernmental agreements which the Parties have entered into or may enter into in order to address different matters and issues as between the Parties which involve RTD's FasTracks program and the City.

**ARTICLE 9  
TERM AND TERMINATION**

This IGA will remain in effect from the Effective Date until final acceptance of the fabrication and installation of all Artwork Tree Wraps by both the City and RTD.

**ARTICLE 10  
REPRESENTATION OF PARTIES**

The parties represent that each has taken all actions that are necessary or that are required by its procedures, bylaws, or applicable law to legally authorize the undersigned signatories to execute this IGA on behalf of the parties and to bind the parties to its terms.

**ARTICLE 11  
SEVERABILITY**

To the extent that this IGA may be executed and performance of the obligations of the parties may be accomplished within the intent of the IGA, the terms of the IGA are severable, and should any term or provision hereof be declared invalid or become inoperative for any reason, such invalidity or failure shall not affect the validity of any other terms or provision hereof.

**ARTICLE 12  
WAIVER AND BREACH**

The waiver of any breach of a term hereof shall not be construed as a waiver of any other term, or the same term upon a subsequent breach.

**ARTICLE 13  
NO THIRD-PARTY BENEFICIARIES**

It is expressly understood and agreed that enforcement of the terms and conditions of this IGA, and all rights of action relating to such enforcement, shall be strictly reserved to the parties, and nothing contained in this IGA shall give or allow any such claim or right of action by any other or third person under this IGA. It is the express intention of the parties that any person or entity other than the parties receiving services or benefits under this IGA be deemed an incidental beneficiary only.

**ARTICLE 14  
CHANGES IN LAW**

This IGA is subject to such modifications as may be required by changes in state or federal law, or their implementing regulations. Any such required modification shall automatically be incorporated into and be part of this IGA on the effective date of such change as if fully set forth herein.

**ARTICLE 15  
INDEPENDENT CONTRACTORS**

The parties are independent contractors and not partners or joint ventures of one another.

**IN WITNESS WHEREOF**, the City and RTD have executed, through their respective lawfully empowered representatives, this IGA as of the day and year above written.

**APPROVED AND RECOMMENDED:**

***CITY OF NORTHGLENN***

APPROVED AS TO FORM

BY: \_\_\_\_\_  
Heather Geyer  
City Manager, Heather Geyer

BY: \_\_\_\_\_  
Corey Hoffmann  
City Attorney

BY: \_\_\_\_\_  
Brook Svoboda  
Director of Planning & Development

**REGIONAL TRANSPORTATION  
DISTRICT**

BY: \_\_\_\_\_  
Chuck Culig  
North Metro Rail Line Project  
Manager

APPROVED AS TO FORM

BY: \_\_\_\_\_  
James Stadler  
Associate General Counsel